

Motion Control Training

Training Equipment and Services



ENGINEERING YOUR SUCCESS.



Systems from a Global Leader



Parker Hannifin is the World's leading diversified manufacturer of motion and control technologies and systems, providing precision engineered solutions for a wide variety of commercial, mobile, industrial, and aerospace markets. Parker's products are vital to virtually everything that moves or requires control, including the manufacture and processing of raw materials, durable goods, infrastructure development, and all forms of transport.

Customers rely on Parker for engineering excellence, World-class manufacturing, and outstanding customer service to provide comprehensive application solutions. Parker's technical training for Hydraulic, Pneumatic, and Electromechanical technology is the best in the World.



Custom Learning Modules

Parker's Motion Control Institute offers a full range of training equipment and curriculum to support the teaching of Hydraulic, Pneumatic, and Electromechanical motion control technologies. Utilized by Colleges, Universities, Technical Schools and industry around the World, Parker's training systems, textbooks, lab manuals, instructor's guides, and teaching aids have been educating technology students for over 40 years.

Training products are available individually, or grouped with other components and curriculum to create custom learning modules. Hundreds of Colleges and Universities use Parker learning modules to educate the next generation of motion and control professionals



Flexible Learning with Parker Solutions

- Parker's Motion and Control Institute offers a full range of training equipment and curriculum to support the teaching of hydraulic and pneumatic motion control technologies. Utilized by Colleges, Universities, Technical Schools and industry around the world, Parker's training systems, textbooks, lab manuals, instructor's guides, and teaching aids have been educating technology students for over 40 years.
- Parker's modular training system is a flexible training platform. The system can be customized to meet the user's needs and budget.
- The components on Parker's training equipment are industrial grade and are used in industry today. Students benefit from learning with the components actually used in demanding real-world applications.
- Training products are available individually, or grouped with other components and curriculum to create custom learning modules. Hundreds of Colleges and Universities use Parker learning modules to educate the next generation of motion and control professionals.

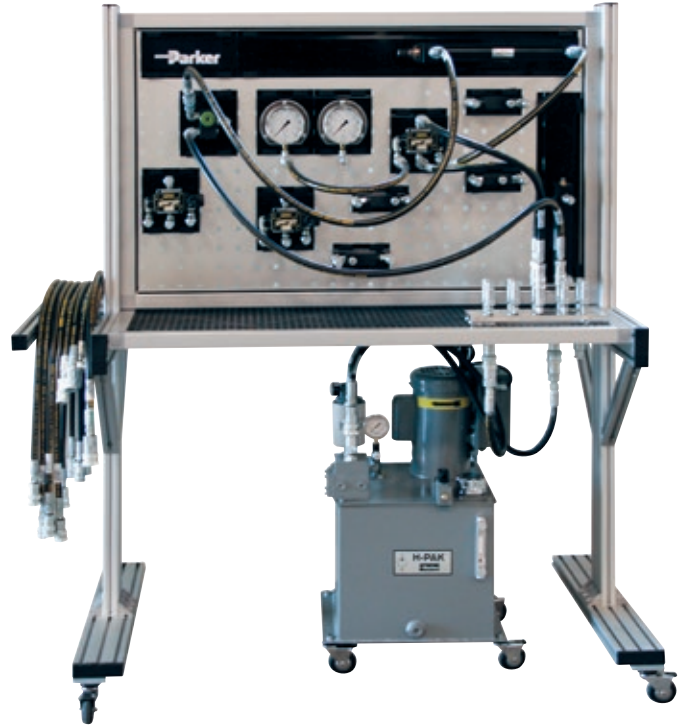

PSKSP0 – Standard Platform

PSKPO – Standard Platform

Part Number	Quantity	Description
PSKMF	1	Modular Frame
PSK-PL48X28	1	Modular Panel
PSKPU1	1	Power Unit
Duraclean	3	Filter & Hydraulic Oil – 5 gal bucket



PSKMF – Modular Frame

The lightweight aluminum frame is ideal for a versatile training environment. Components from any learning module easily snap onto the panel in any configuration. An additional panel (PSK-PL48X28) can be mounted to the back for a double-sided learning platform.

Circuits can be created with ease and brought into the classroom to reinforce learning objectives.

- 68" high x 54" wide x 31" deep
- 4" swivel locking casters
- Hose rack

PSKPU1 – Power Unit

The industrial power unit is used in many hydraulic applications and connects directly to any of the hydraulic components or through a manifold (PSK20600). It offers a huge training opportunity for students to learn about industry standards and proper maintenance. Also includes 15 gallons of Hydraulic Oil.

Power Unit

- 1 horsepower
- 115 volt electric motor
- Pressure gauge
- Filter
- Motor starter
- Tank gauge
- Bypass valve
- Swivel locking casters



Hydraulic Oil

- Formulated for high performance hydraulic power units and equipment
- Formulated to help extend the life of hoses and seals
- Superior thermal stability for uncompromised performance at high temperatures



BHLM01 & BHEM02 – Basic Hydraulic Learning Modules

The BHLM01 Basic Hydraulic Learning Module includes fourteen experiments to provide hands-on learning. All of the components in this module are mounted on individual fixtures that snap onto the modular panels.

BHLM01 – Basic Hydraulic Learning Module

Part Number	Quantity	Description
PSK20600	2	Manifold
PSK20600A	1	Manifold with SensNODE
PSK20601	1	Closed Center Lever Operated Valve
PSK20604	1	6" Double-Acting Cylinder
PSK20606	4	Tees
PSK20607	13	Hose Assemblies
PSK20608	1	Needle Valve
PSK20609	1	Flow Control Valve with Bypass Check
PSK20610	1	Check Valve
PSK20611	1	Pressure Compensated Flow Control Valve
PSK20612	1	Flow Meter
PSK20614	1	Pressure Reducing Valve
PSK20615	2	0-1000 psi Gauges
Bulletin 0216-B8-R1	1	Student Lab Manual
Bulletin 0216-B2-R1	1	Instructor Lab Manual

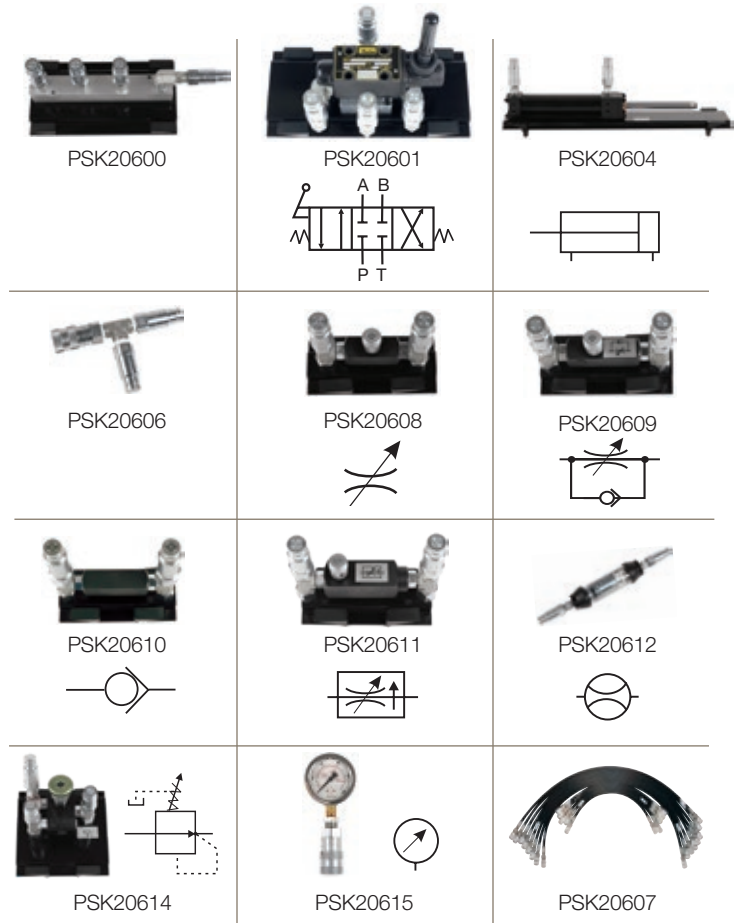

The BHEM02 Basic Hydraulic Expansion Module combines with the BHLM01 Basic Hydraulic Module to allow for an additional seventeen experiments.

BHEM02 – Basic Hydraulic Expansion Module

Part Number	Quantity	Description
PSK20602	1	3-position, 4-way, Open Center Lever Operated
PSK20603	1	12" Double-acting Cylinder
PSK20609	1	Flow Control Valve with Bypass Check
PSK20610	1	Check Valve
PSK20613	1	Sequencing Valve
PSK20618	1	Bidirectional Gerotor Motor
Bulletin 0216-B8-R1	1	Lab Manual

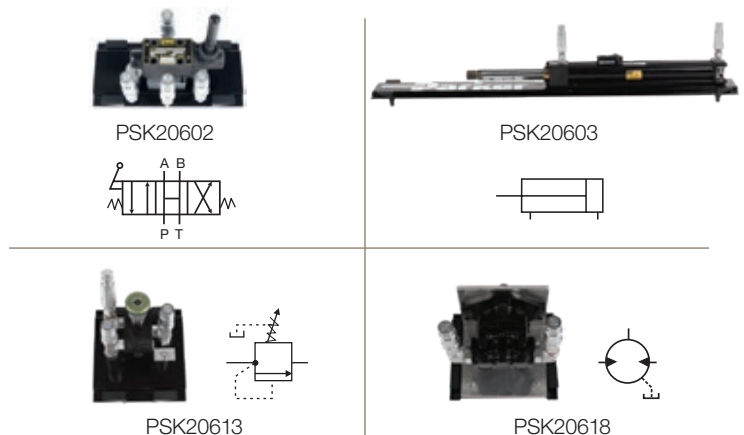



Lab Manual – Bulletin 0216-B8-R1

BHLM01

Lab Manual Learning Exercises:

- Maximum Relief Pressure
- Flow Rate of Pump
- Standard Closed Center Circuit
- Setting Flow Rate Through a Flow Control Valve
- Cylinder Leak Test
- Regeneration
- Measuring Flow Out of a Cylinder
- Meter-In
- Meter-Out
- Meter-Out With Pressure Compensated Control Valve
- Bleed-Off Flow Control, Retract
- Bleed-Off Flow Control, Bidirectional
- Pressure Reducing Valve Adjustment
- Pressure Reducing Circuit



BHLM02

Lab Manual Learning Exercises:

- Standard Open Center Circuit
- Closed Center Pressure Buildup
- Regeneration Without Full Flow Through Directional Valve
- Synchronize on Extend Only
- Synchronize Both Ways Without Flow Control
- Hydraulic Motor Meter-In Flow Circuit
- Hydraulic Motor Meter-Out Flow Circuit
- Flow Divider
- Counterbalance
- Counterbalancing a Hydraulic Motor
- Sequence Valve Adjustment
- Sequencing Cylinders
- Sequencing Cylinder and Motor
- Sequencing and Pressure Reducing
- Crossover Relief
- Tri Pressure System
- Directional Control Without Directional Control Valve (Introductory Lab for Cartridge Valve Systems)

Curriculum

Additional learning exercises simulate thousands of real world applications.

The BHEM02 basic hydraulic expansion module utilizes the same textbook, instructor guide, as the BHLM01 basic hydraulic module.

MHLM01 – Mobile Hydraulic Module

Our new Mobile Hydraulic Module features a mobile, two spool proportional valve. It is configured to highlight metering in both the open and closed center mode.

The valve has the capacity for simultaneous metering of two actuators. It also can be configured to show the power beyond function plus much more.

The valve itself is a current production model used in real world applications.

MHLM01 – Mobile Hydraulic Module

Part Number	Quantity	Description
MOB50600	1	Mobile Valve Assembly- Lever Operated
Bulletin 0274-B8.1	1	Mobile Hydraulic Technology Lab Manual

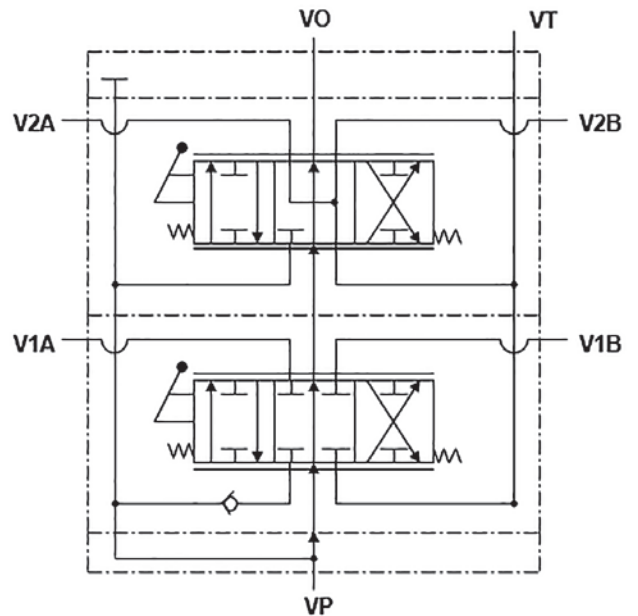

Mobile Hydraulic Technology Lab Manual – Bulletin 0274-B8.1

Learning Exercises:

- Simple Circuit –Open Center
- Simple Circuit – Closed Center
- Operating a Cylinder with a Float Section
- Multiple Circuit – Splitting with an Open Center Valve
- Multiple Circuit – Splitting with a Closed Center Valve
- Measuring Flow out of a Cylinder
- Regeneration
- Pressure Reducing Valve Adjustment
- Pressure Reducing Circuit
- Sequence Valve Adjustment
- Sequencing Cylinders
- Sequencing a Cylinder and Motor
- Meter – In
- Meter – Out
- Synchronize Cylinders with Flow Controls
- Synchronize Cylinders Both Ways without Flow Controls
- Closed Center Pressure Build-up
- Cylinder Leak Test Power Beyond Circuit



EHTM07 – Electrohydraulic Module

Learn the skill of Open and Closed loop control exactly as you would in the real world. Automatic control of hydraulic systems has evolved into an increasingly superior alternative for many industrial applications. Advances in hydraulic hardware and electronics have combined to make the design and installation of these systems more intuitive, reliable, cost effective, repeatable and user friendly.

Controlling the position of a cylinder is one of the more demanding hydraulic motion control techniques. The electrohydraulic module is intended to develop a solid background in controlling the position of a cylinder, along with references to controlling velocity, pressure, force and combinations thereof.

EHTM07 – Electrohydraulic Module

Part Number	Quantity	Description
SKHD1FB	1	Servo/Proportional Valve and cylinder
SKPID	1	Signal Conditioning Card
SKPS2401	1	Power Supply 24 Volt - 4 Amps
SKPDS	1	Potentiometer
SKEHC	1	7-pin Valve Cable
SK0866	1	Cylinder Cable
	1	Parametrizing Cable
Bulletin 0217.1	1	Electrohydraulic System Engineering Lab Manual

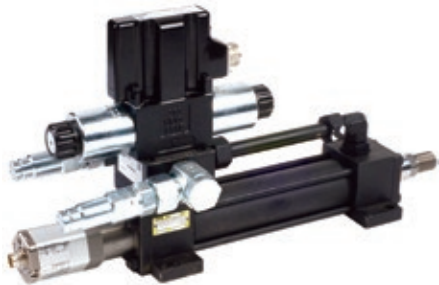

SKHD1FB

SKHD1FB Servo/Proportional Valve and Cylinder

This Electrohydraulic Axis is the heart of hydraulic control in many applications. The proportional directional valve is available with digital onboard electronics. The valve parameters can be saved, changed and duplicated in combination with the digital power amplifier. The cylinder feedback is a magnetostrictive probe common in high end applications.

- Digital onboard electronics.
- ProPxD software available on the internet.
- Set Ramps, Limits and Dead-band with your computer
- Command options for D1FB +/- 10V
- Plot spool command and linearization
- Manual override



SKPID / SKPS2401

SKPID Signal Conditioning Card

The digital servo amplifier unit combines all necessary functions for the optimal operation of closed loop controls. The most important features are:

- Extended PID controls
- Speed control with position feedback
- Differential input stage with different signal options
- Output stage with different output options
- Four-quadrant ramp function
- Status indicator
- Digital circuit design
- Connection by disconnectable terminals
- Compatible to the relevant European EMC standards



Electrohydraulic Training Module ENTM07 Lab Manual – Bulletin 0217-B8-R1

Learning Exercises:

- Electrohydraulic Valve
- LVDT (linear variable differential transformer)
- PC Board Input/Output Connections
- “On Board” Driver Card Current and Bias Options
- “On Board” Driver Card Electronic Limits
- “On Board” Driver Card Deadband Compensators
- Open Loop Operation with Cylinder
- Proportional Valve Characteristics
- Open Loop Operation with a Motor
- Closed Loop Operation with a Cylinder



BPLM01 – Pneumatic Learning Module

The BPLM01 Basic Pneumatic Learning Module includes fifteen experiments to provide hands-on learning. All of the components in this module are mounted on individual fixtures that snap into the modular panels.

The lab manual (Bulletin 0213-B8) describes the step-by-step procedures for all of the experiments and references the learnings of the Pneumatic Technology for Industry student textbook.



BPLM01 – Pneumatic Learning Module

Part Number	Quantity	Description
BPT30600	2	Single Rod Cylinder
BPT30601	1	Double Rod Cylinder
BPT30602	1	5/2 Manual Hand Valve
BPT30603	3	3/2 Manual Hand Valve
BPT30604	3	Quick Exhaust/Shuttle Valve
BPT30605	2	3/2 Single Air Pilot Valve
BPT30606	5	5/2 Double Air Pilot Valve
BPT30607	1	Filter-Regulator with Gauge
BPT30608	2	Regulator with Gauge
BPT30609	5	In line Flow Controls; 1/4" Tube
BPT30610	1	1/4" Tube Check Valve
BPT30611	1	Six Port Junction
BPT30612	3	Quad Junction
BPT30613	5	Tee
BPT30614	13	Plug
Bulletin 0213-B8	1	Lab Manual



BPT30600



BPT30601



BPT30604



BPT30607



BPT30610



BPT30613



BPT30602



BPT30605



BPT30608



BPT30611



BPT30614



BPT30603



BPT30606



BPT30609



BPT30612

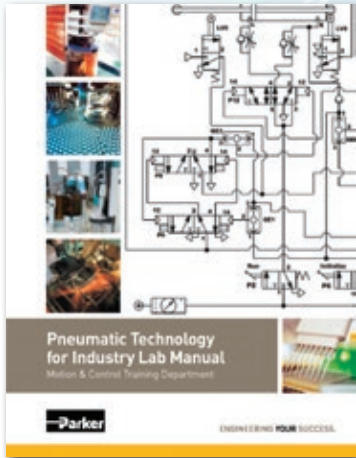

Pneumatic Technology for Industry Lab Manual – Bulletin 0213-B8-R1

Learning Exercises:

- Operating a cylinder with two 3-way, 2-position valves
- Use of a 5-way, 4-position valve to actuate a double acting cylinder
- Use of a spring applied, air pressure released rodlock to restrict cylinder motion
- Controlling a large valve using a smaller valve, using pneumatic control
- Use of a quick exhaust valve to open an actuator very quickly
- Pneumatic circuit that will cycle automatically
- Automatic circuit with two stop signals – momentary and retained
- Control system that converts a momentary pressure signal into a sustained pressure signal
- Automatic reciprocating circuit that does not use the limit valves
- Pneumatic sequencing circuit
- Two pressure pneumatic circuit
- Energy conservation circuit
- Using limit valves to cause cylinder's motion to precede another
- Two speed circuit
- 3 position circuit using a duplex cylinder



EHEM02 – Electrohydraulic Expansion Module

Digital motion controllers transform the way hydraulic systems function in today's demanding applications. Profiles are entered into the motion controllers with the expectation that the electrohydraulic system will closely follow the profile. This module is designed to explore all the variables that affect the performance of these systems.

SKC3F01

The Compax3F was especially designed to meet the requirements of electrohydraulic systems for the control of position and force of hydraulic axes.

Motion control with motion profiles was created with Standard IEC 61131-3. The motion control functions specified in PLC open are also provided by Parker as a library with the device and control software.

SKRS232-Cable

This cable is required to communicate with the SKC3F01 Controller.



EHEM02 – Electrohydraulic Expansion Module

Part Number	Quantity	Description
SKC3F01	1	Compax3F Controller
SKRS232	1	Cable



Ask about the new EHEM03 PACHC Electrohydraulic Expansion Module using the new PAC120 Motion Controller with PACHC Hydraulic Control Card

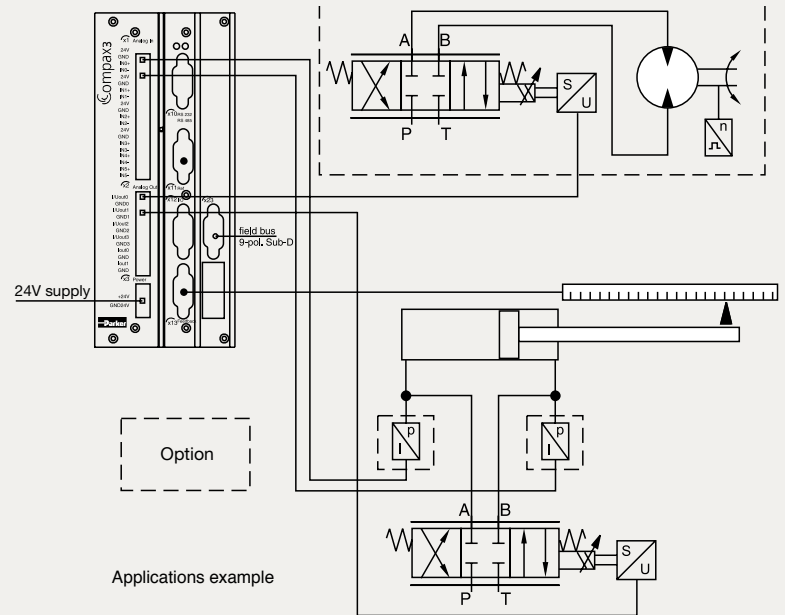



Triad Technologies
985 Falls Creek Drive
Vandalia, OH 45377
phone (800) 420-8575
info@triadtechnologies.com



Parker Hannifin Corporation
Motion & Control Training Dept. W3MC01
6035 Parkland Blvd.
Cleveland, OH 44124-4141
phone (216) 896-2495
www.parker.com/training
mctrain@parker.com